



**The trend of
contraceptives appliance
and
its supply chain**

● **Indonesian experience**

Presented by
Hendra Gunawan
PT Tunggal Group

**Your reliable partner
in Reproductive Healthcare**



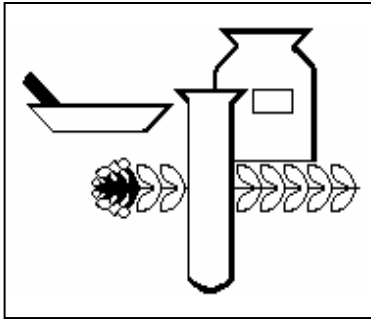

Driving



*to bring
the co'y vision & mission*



closer...

faster...

The trend of contraceptives appliance

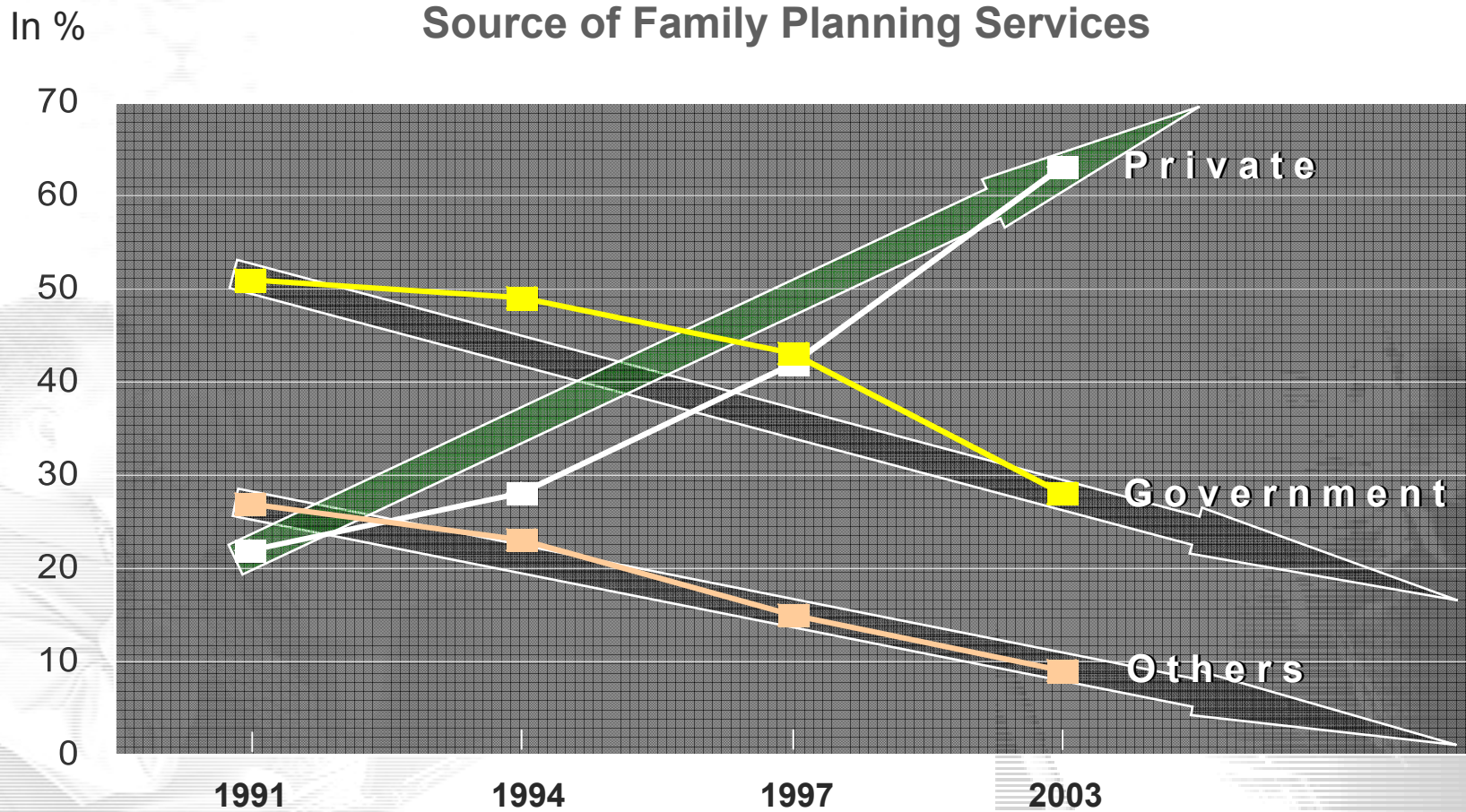

SDKI : Survey on Indonesian Demography and Health

The trend of contraceptives appliance

Source of Family Planning Services Private sector

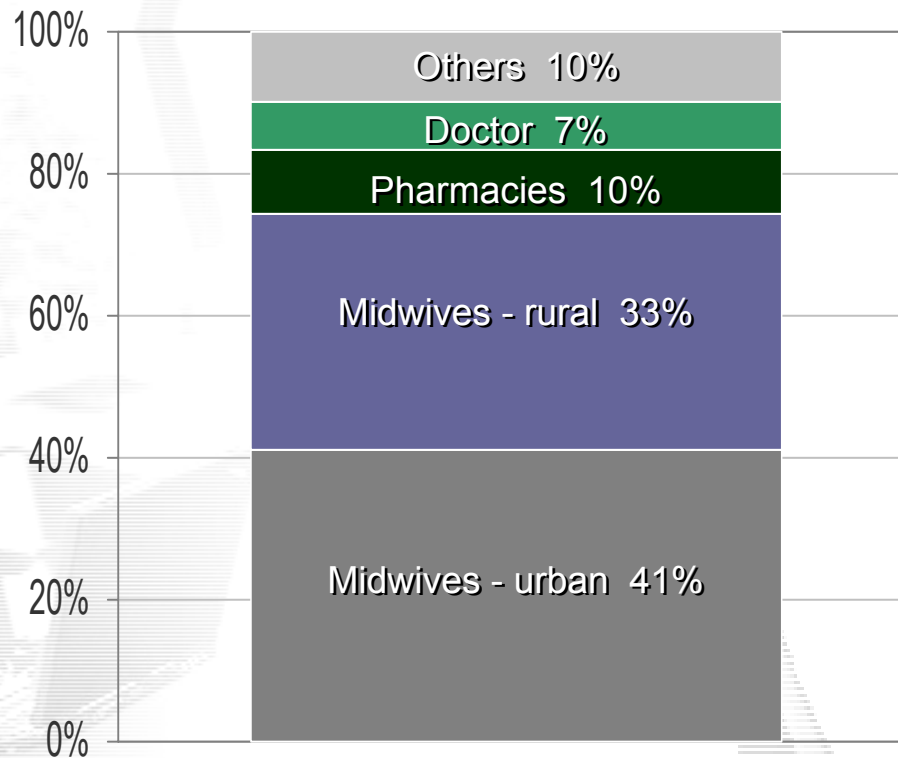

SDKI : Survey on Indonesian Demography and Health

The trend of contraceptives appliance

Trend of contraceptives application

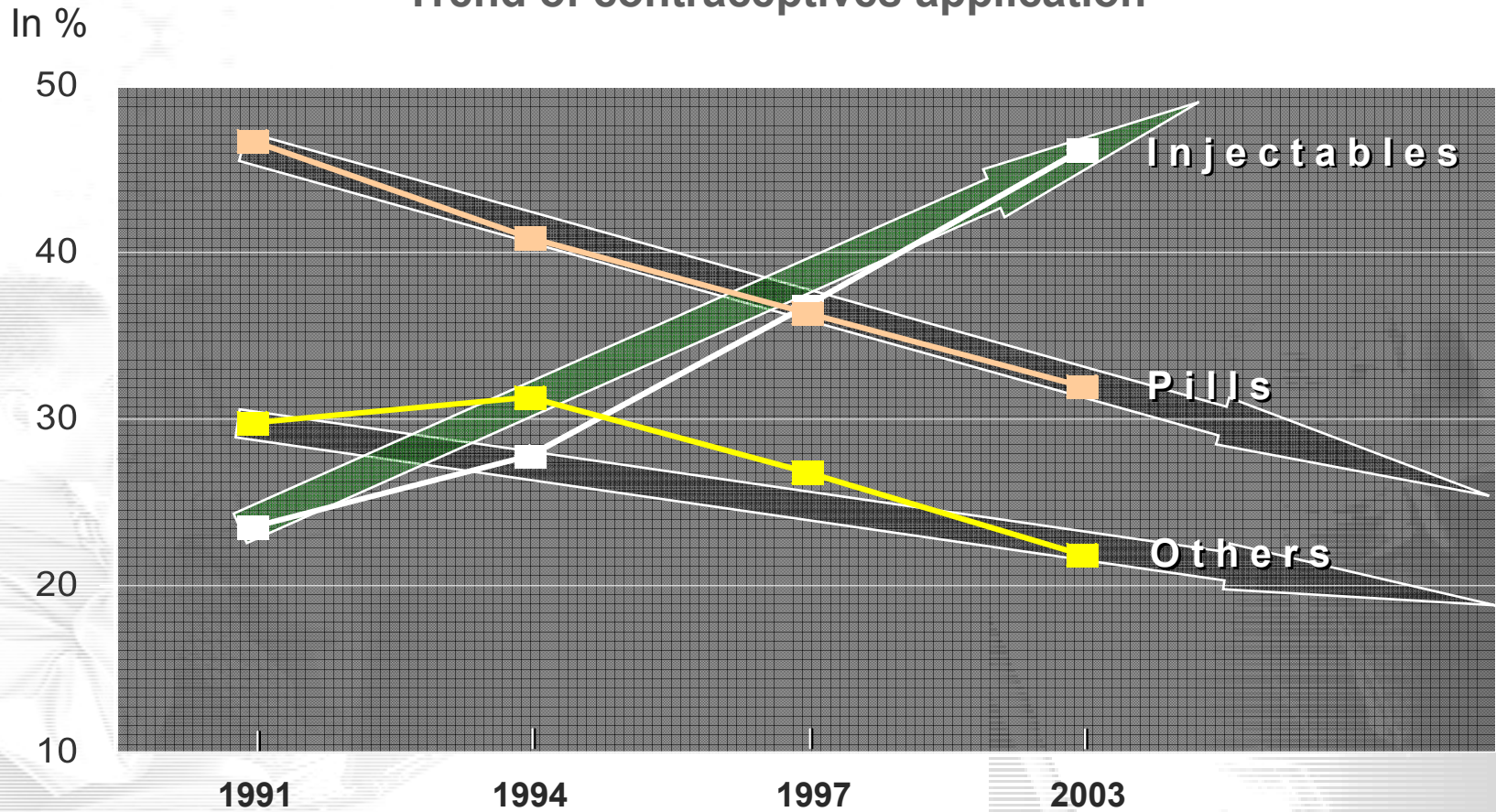

SDKI : Survey on Indonesian Demography and Health

The trend of contraceptives appliance

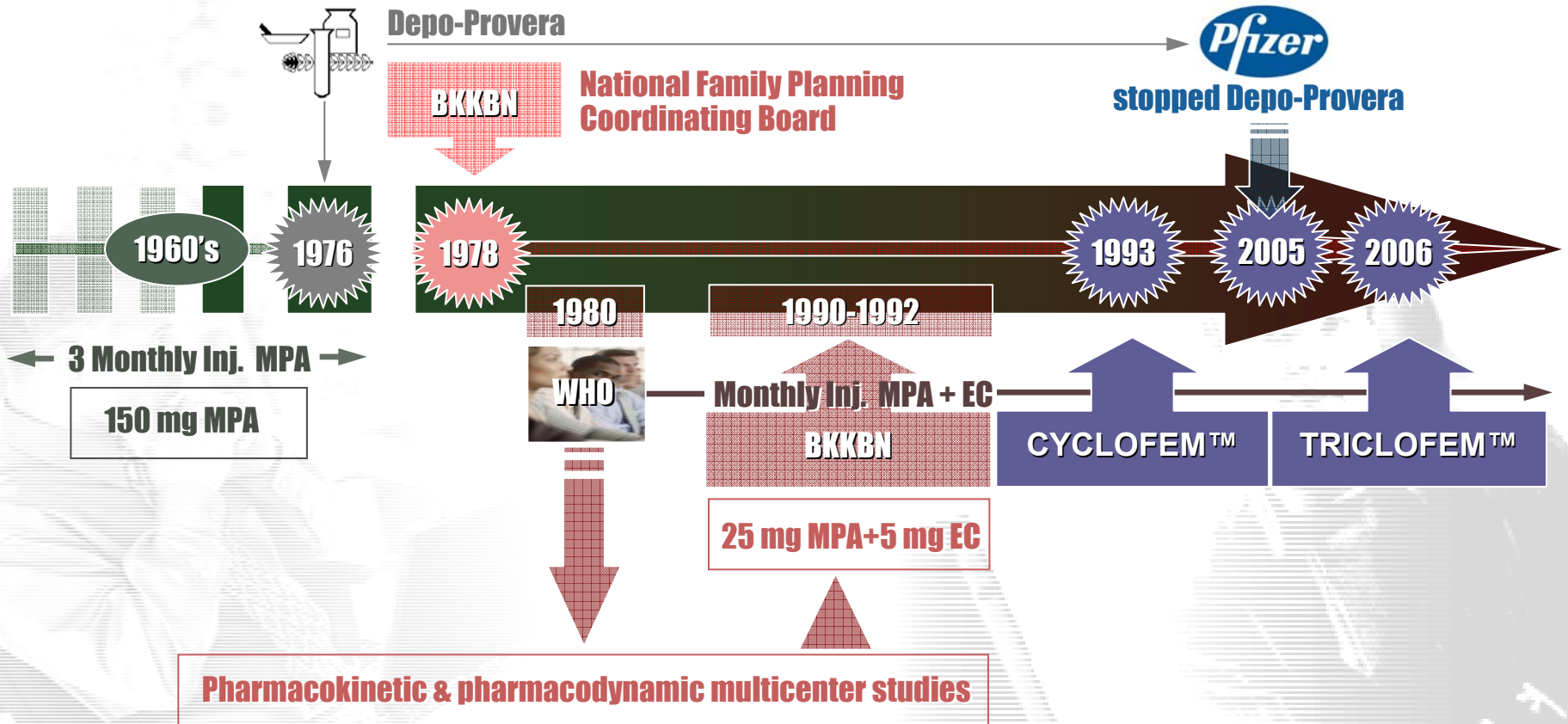

The trend of contraceptives appliance

Trend of contraceptives application Injectables

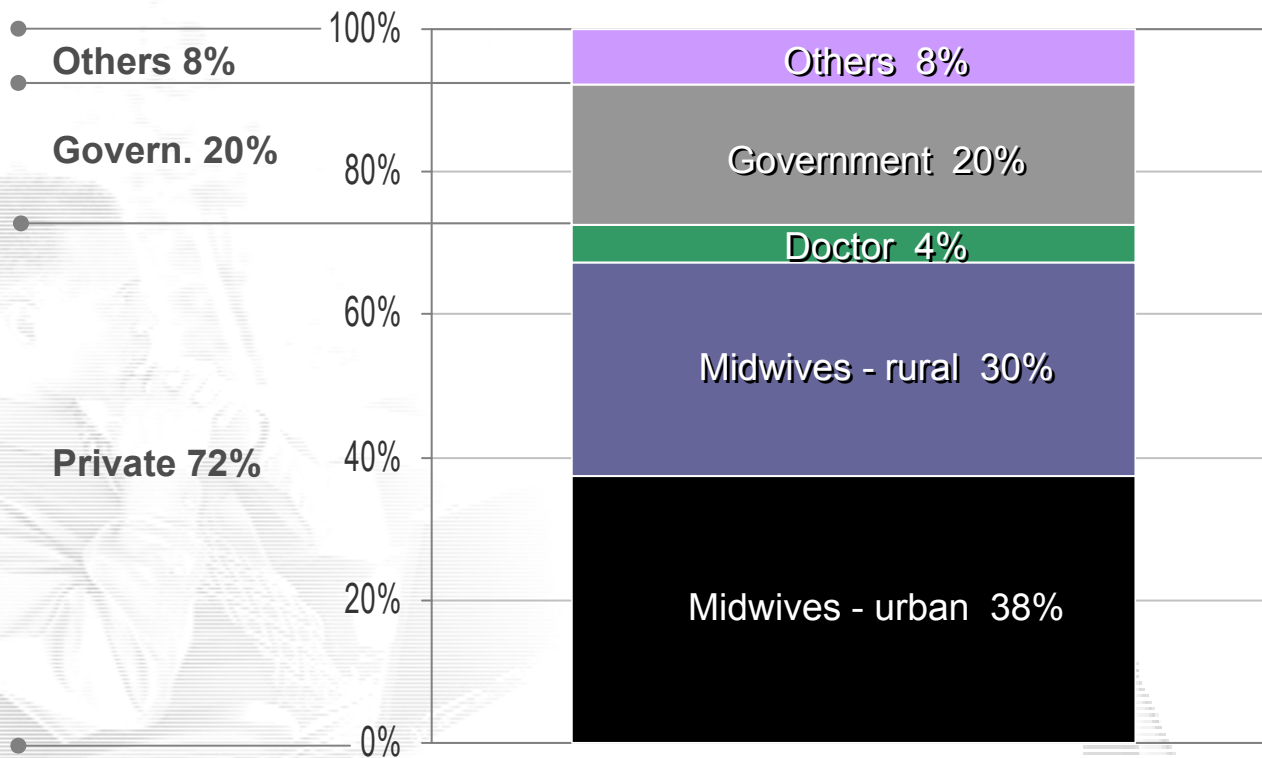

SDKI : Survey on Indonesian Demography and Health

The trend of contraceptives appliance

Trend of contraceptives application Pills

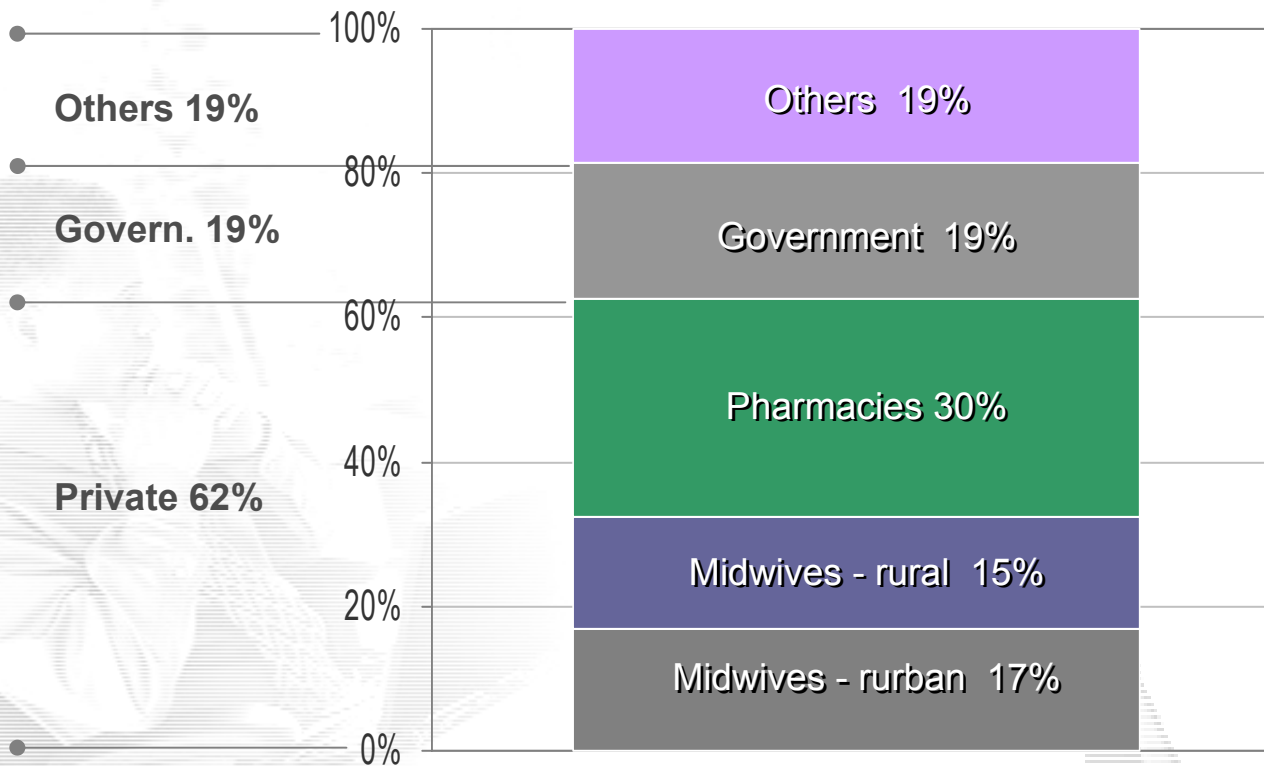

SDKI : Survey on Indonesian Demography and Health

The potential demand

Fertile couples 42 m

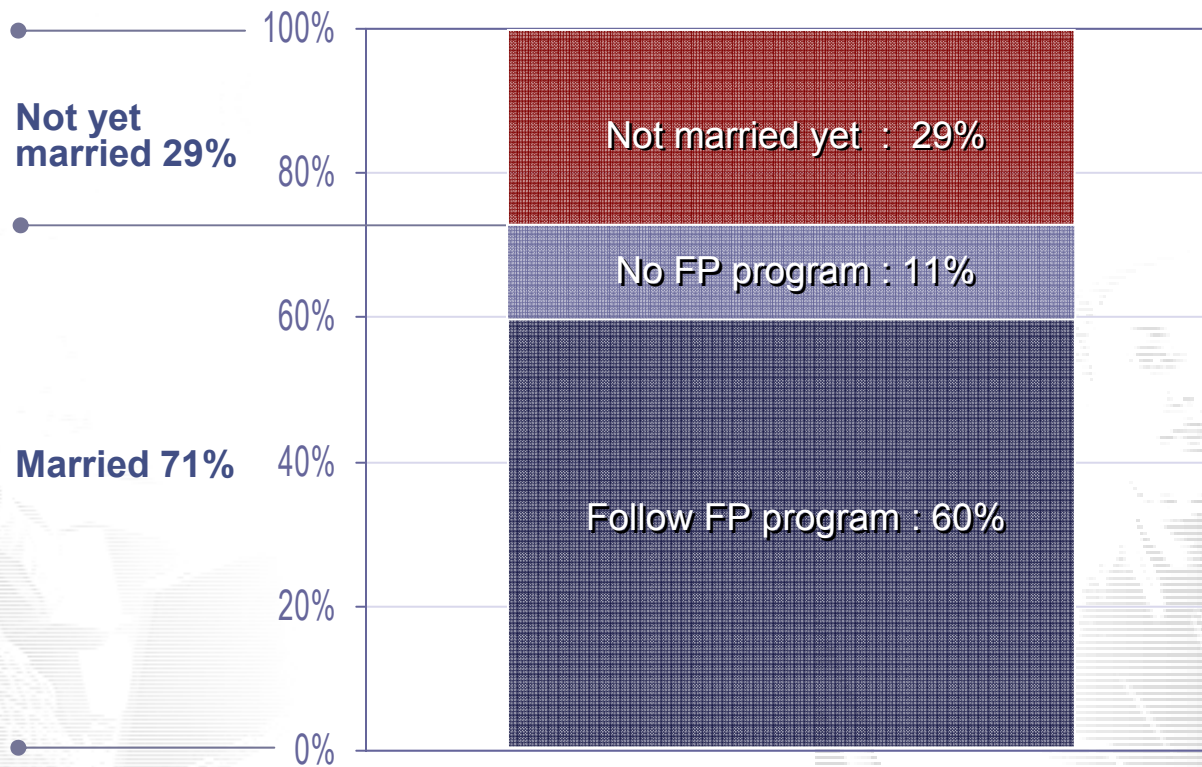

SDKI : Survey on Indonesian Demography and Health

The potential demand

Number of fertile couples = 42 mio

Number of acceptors = 60% X 42 mio = 25.2 mio

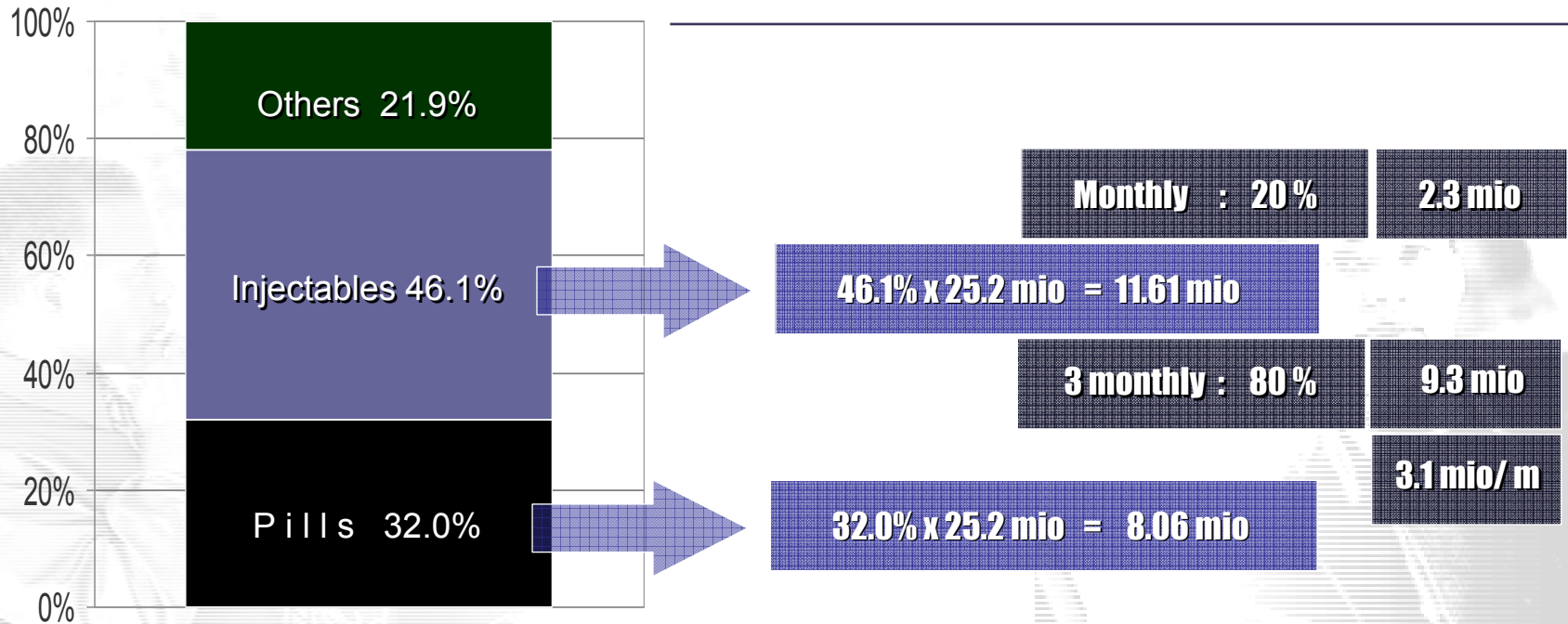

Trend COCs of Indonesian Pharmaceutical Market

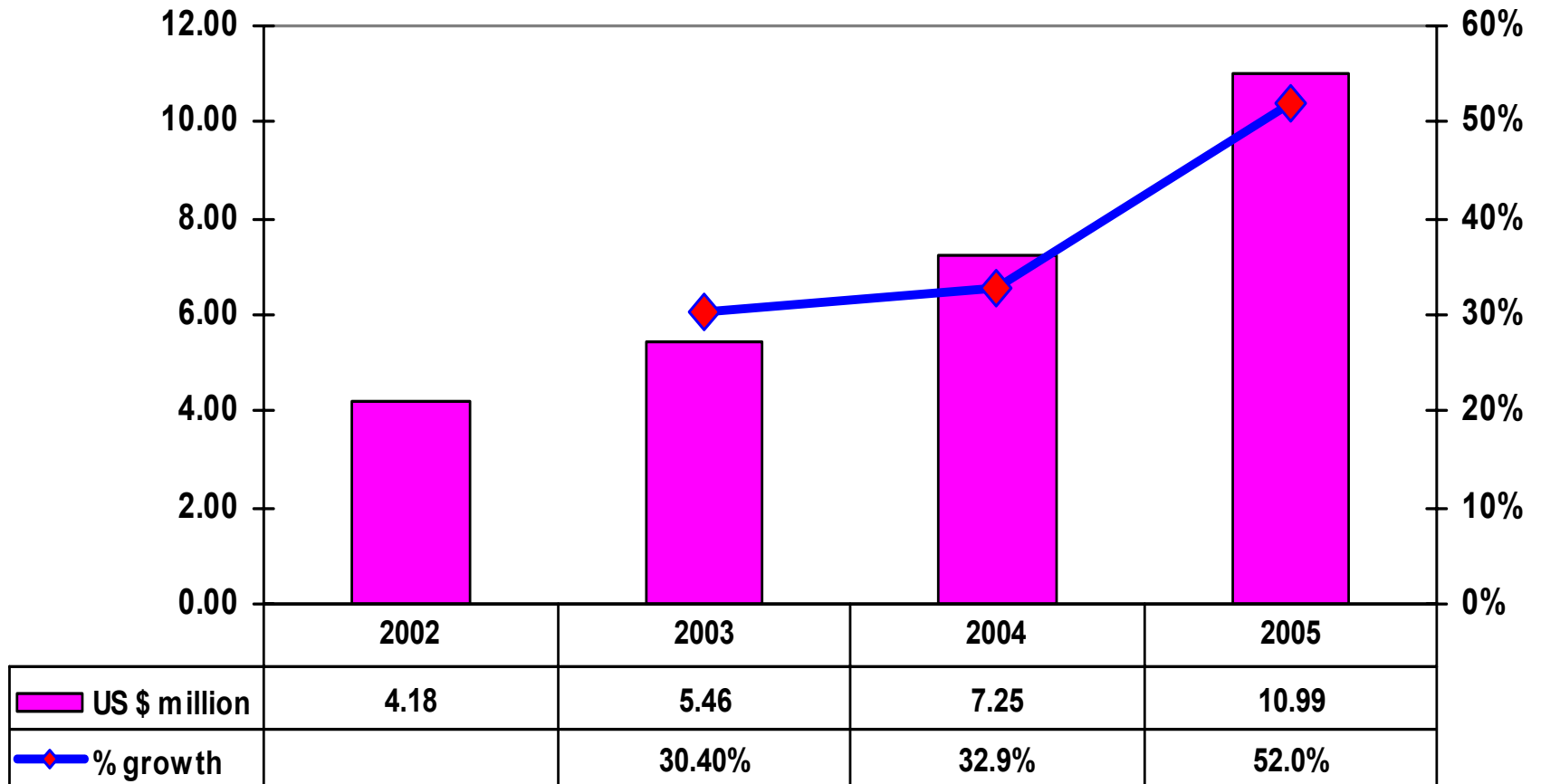

Total Market of COCs 2002-2005 (5 players)

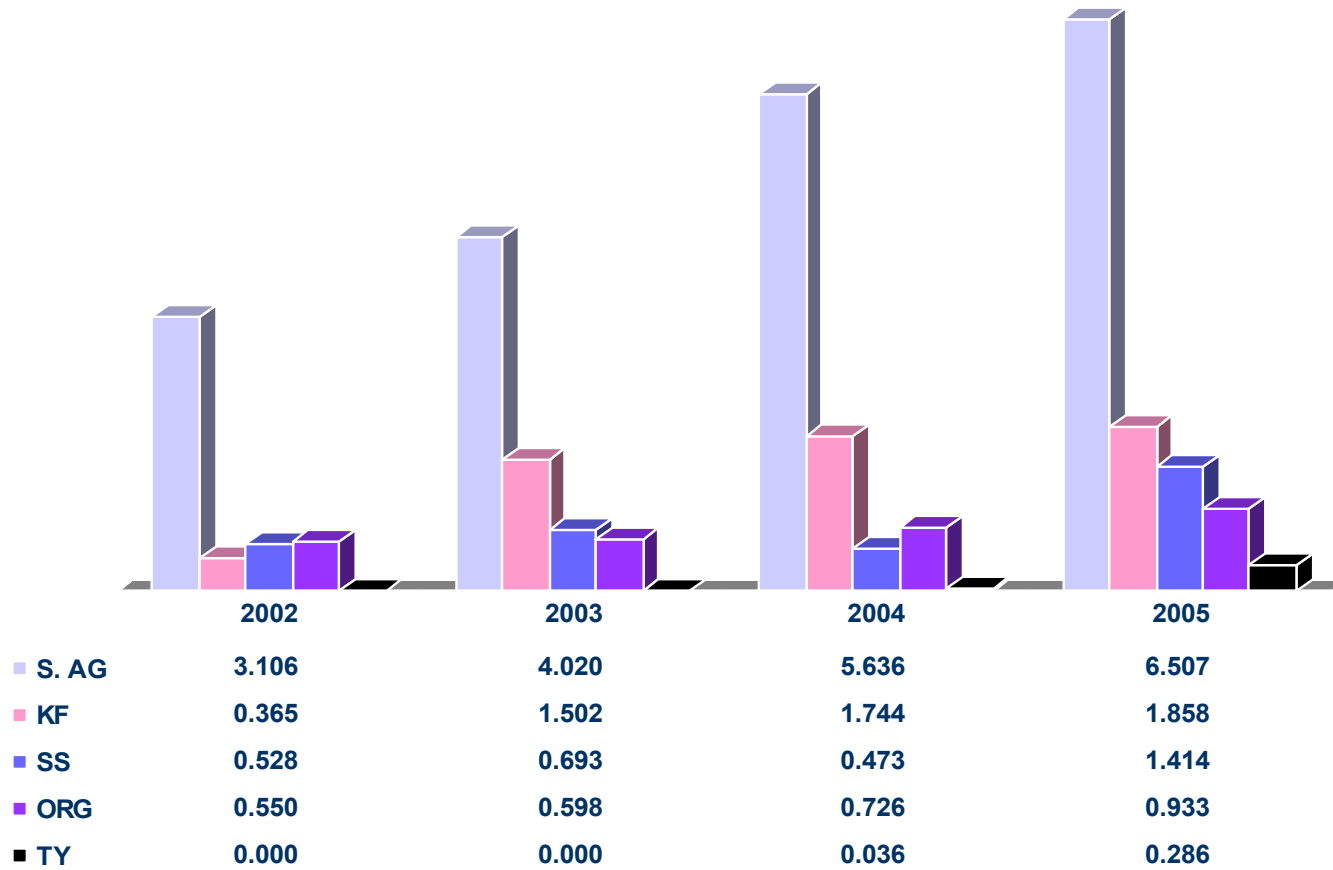

Market Share of COCs in 2005

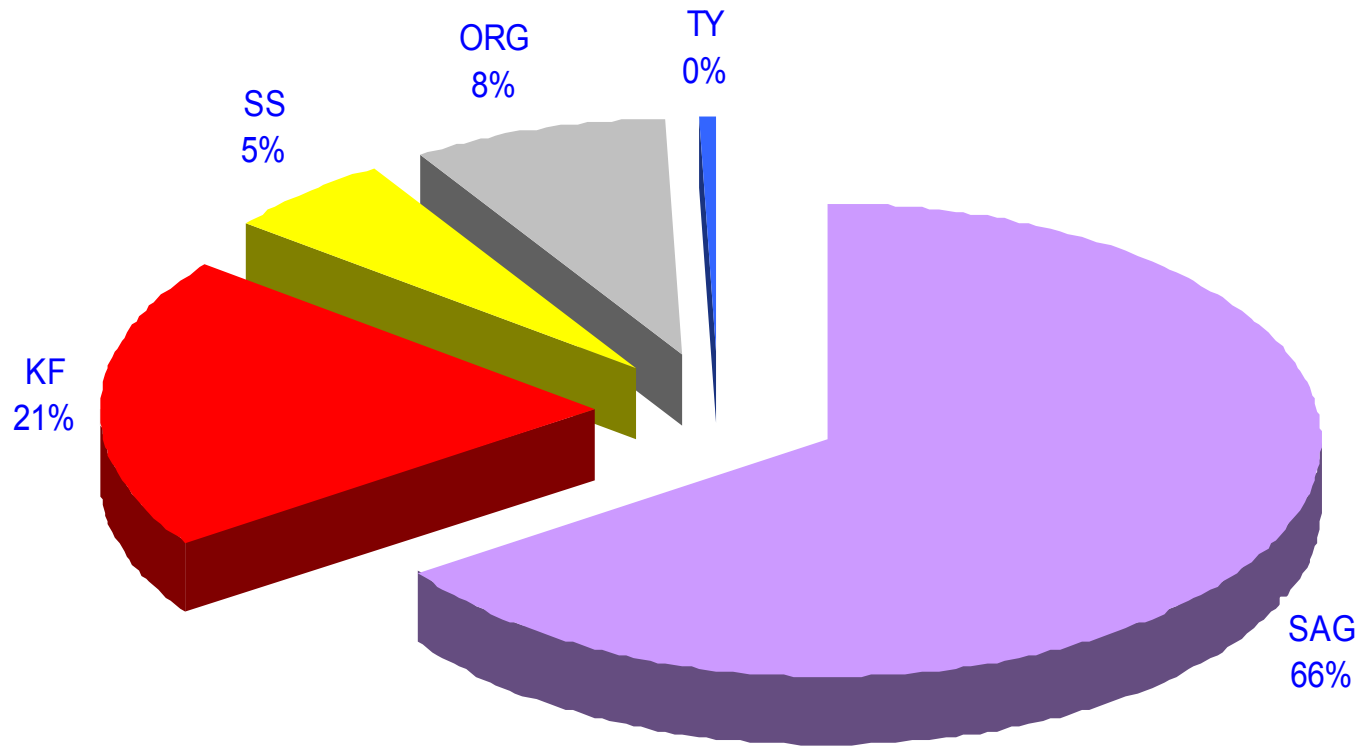

Trend of Mikrodiol in Indonesia Market

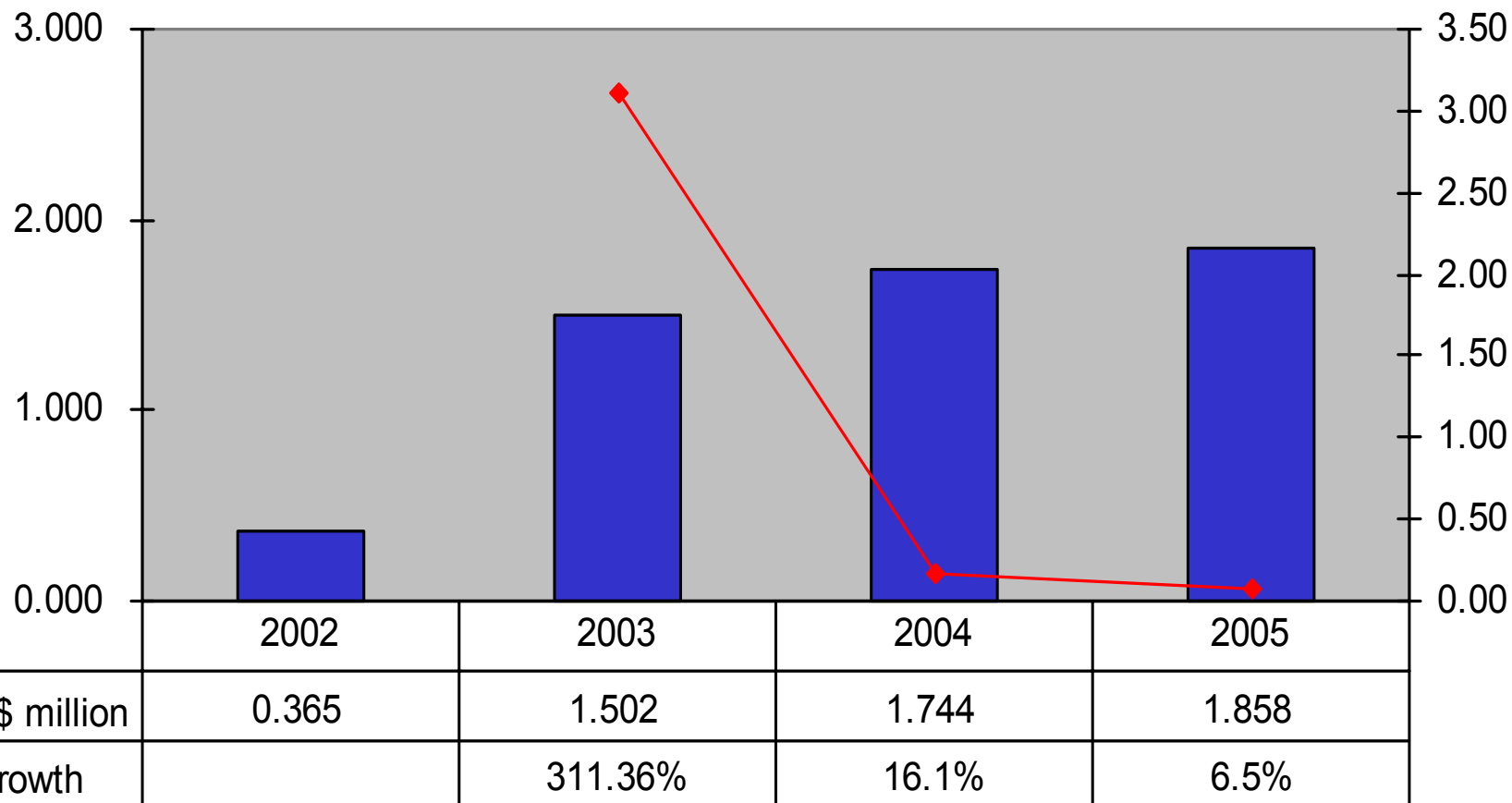

Source : IMS Health



**What's
the bottom line...?**

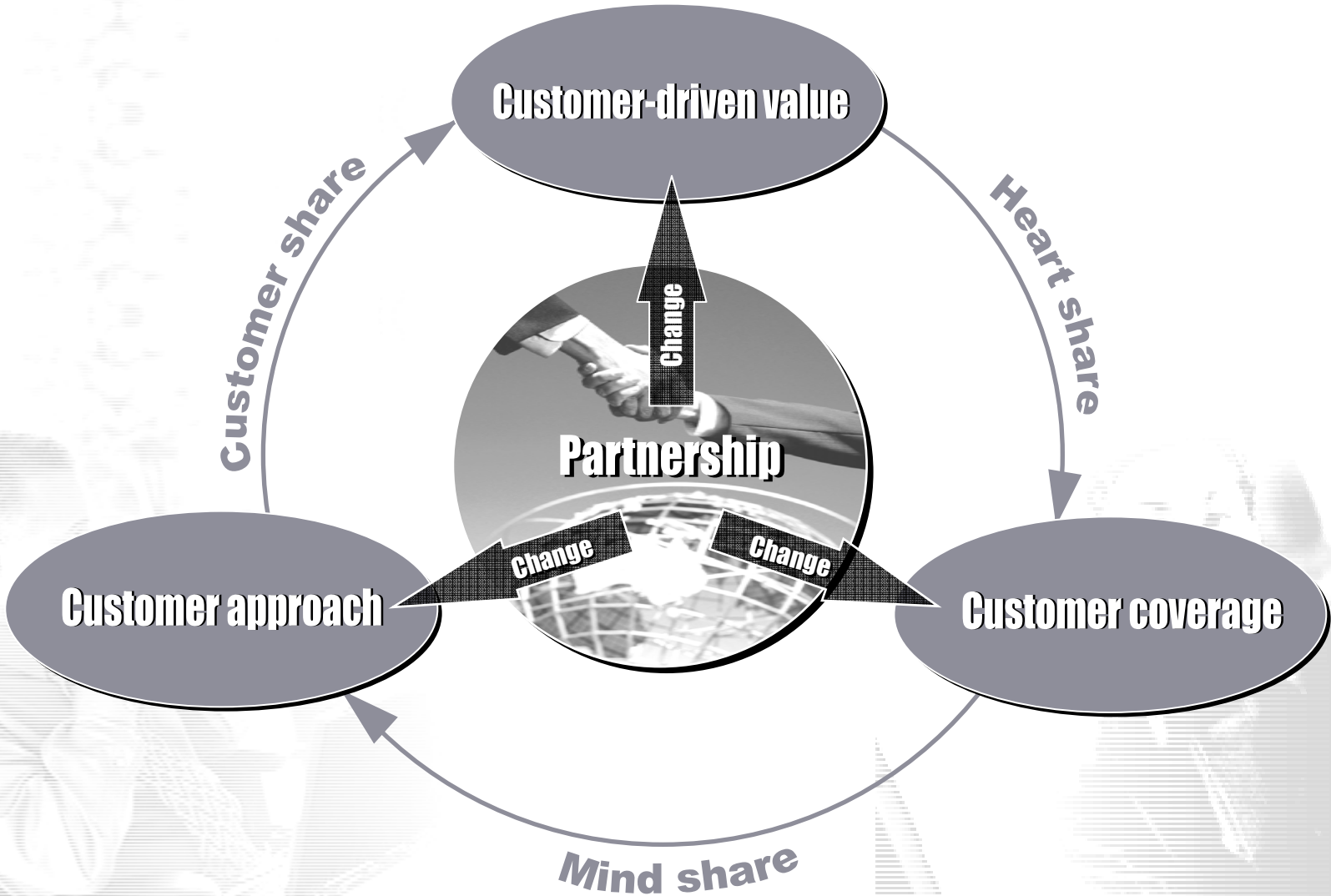

Customer-driven value

Customer share

Heart share

Partnership

Change

Customer approach

Change

Change

Customer coverage

Mind share



Let's dance

Diversification of F/P
program into private sector

Access
to  all potential acceptors

Networking through
partnership  arrangement

Customer-driven value
Speed . Quality . Service

Expansion
horizontally & vertically

Let's
DANCE



**Thank you
for
your attention**

Plan our work — Work our plan

For further enquiries
please see us at our exhibition desk

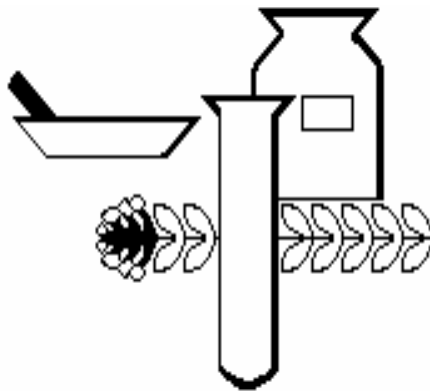

Cyclofem[®]

Monthly injectable contraceptive

Triclofem[®]

3-monthly injectable contraceptive